



# 40' Self Powered Stacking Conveyor

Optional  
Power Pack



W/ OPTIONAL  
2 CYD HOPPER



9 Gal Hyd. Tank

40' Stacking Conveyor  
With Standard Boot

40' Stacking Conveyor  
W/ Optional Hopper Boot

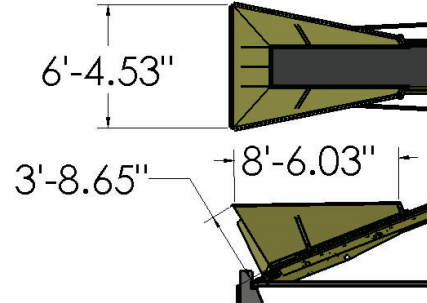

Transport Mode

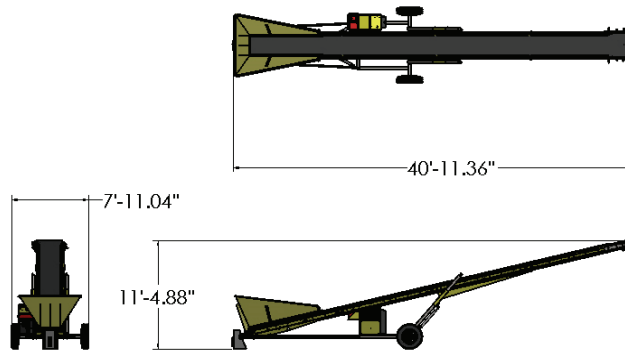

Stacking Mode

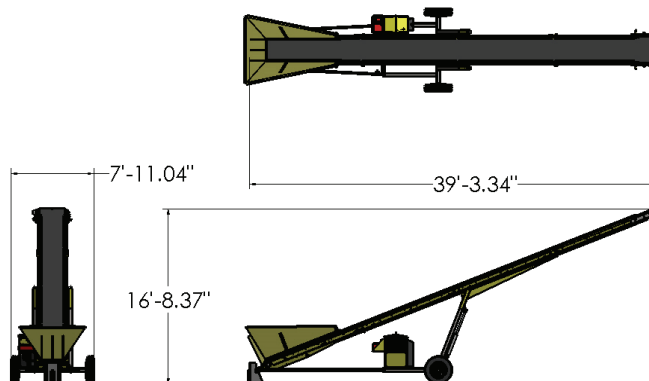

TYPICAL ANGLE OF REPOSE	
MATERIAL	DEGREE
ASPHALT(CRUSTED)	30-45
BARK (WOOD REFUSE)	45
CLAY (DRY)	25-40
EARTH	30-45
GRAVEL (LOOSE DRY)	30-45
GRAVEL(NATURAL W/SAND)	25-30
SAND (DRY)	34

APPROXIMATE PILE CAPACITIES  
 CALCULATED AT 1 TO 1.5  
 ANGLE OF REPOSE (33.69°)