

ORBIT SCREENS, INC
 406 AIR PARK DR PRENTICE, WI 54556
 (715) 428-2000
 www.orbitscreens.com

20', 30' AND 40' CONVEYORS



TYPICAL ANGLE OF REPOSE	
MATERIAL	DEGREE
ASPHALT CRUSTED	30-45
BARK (WOOD REFUSE)	45
CLAY (DRY)	25-40
EARTH	30-45
GRAVEL (LOOSE DRY)	30-45
GRAVEL (NATURAL W/SAND)	25-30
SAND DRY	34

TO SCALE COMPARISONS OF
 20' 30' & 40'
 STAND ALONE CONVEYORS

APPROXIMATE PILE CAPACITIES
 CALCULATED AT 1 TO 1.5
 ANGLE OF REPOSE (33.69°)

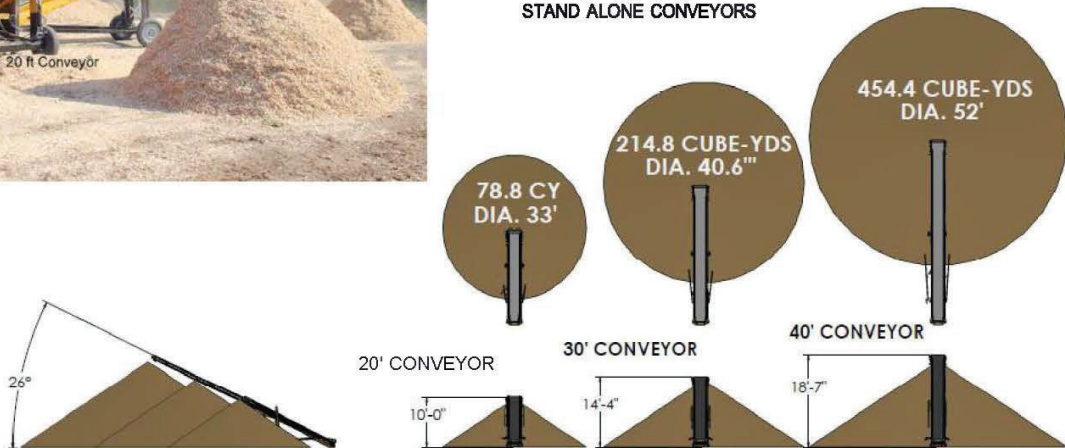



40' Self Powered Stacking Conveyor

Optional
Power Pack



W/ OPTIONAL
2 CYD HOPPER



9 Gal Hyd. Tank

40' Stacking Conveyor
With Standard Boot

40' Stacking Conveyor
W/ Optional Hopper Boot

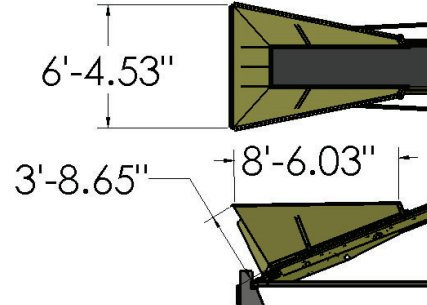

Transport Mode

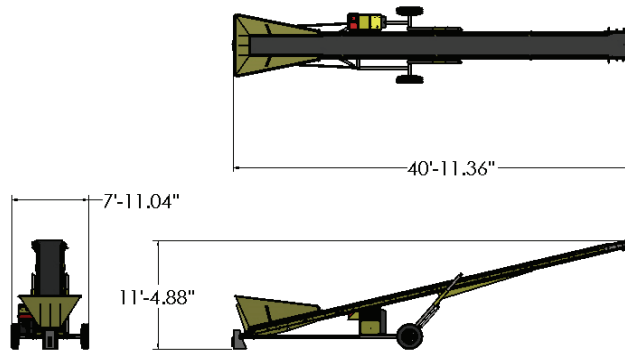

Stacking Mode

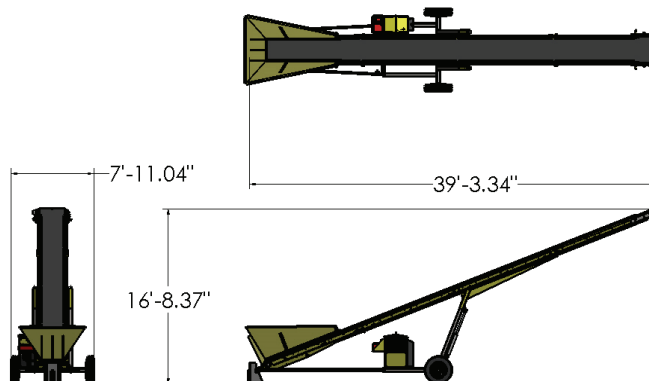

TYPICAL ANGLE OF REPOSE	
MATERIAL	DEGREE
ASPHALT(CRUSTED)	30-45
BARK (WOOD REFUSE)	45
CLAY (DRY)	25-40
EARTH	30-45
GRAVEL (LOOSE DRY)	30-45
GRAVEL(NATURAL W/SAND)	25-30
SAND (DRY)	34

APPROXIMATE PILE CAPACITIES
 CALCULATED AT 1 TO 1.5
 ANGLE OF REPOSE (33.69°)